

*AIR SAFE TOWER FIFTH WHEEL HITCH  
SYSTEM*

**LIMITED 2 YEAR WARRANTY**

The Air Safe Tower Fifth Wheel Hitch System is warranted against defects in material and workmanship under normal use and service, ordinary wear and tear excepted, for 2 years from the first date of purchase at retail. Any part found to have a defect in material or workmanship, will be repaired or replaced at the manufacturer's option when returned with transportation charges prepaid. Include a copy of the original sales receipt when returned for warranty. This warranty does not cover the condition, durability or appearance of the finished product.

If the hitch is damaged as a result of improper installation, alteration, vehicle accident, misuse of unreasonable use, including but not limited to , loading the product beyond the factory rated load capacity, the manufacturer shall not be required to repair or replace such product. In every case, this warranty covers only the defective part and does not provide for reimbursement of the retail price of the part or labor charges.

The manufacturer shall not be liable for any incidental or consequential damages for breach of any express or implied warranty.

There are no warranties that extend beyond the description on the face hereof. The manufacturer is extending no other warranties, express or implied, nor any warranties of merchantability or fitness for a particular purpose. Any such warranties of merchantability or fitness for a particular purpose are expressly excluded.

This warranty is designed and intended to fully comply with the requirements of the Magnusson-Moss Warrant Act and all regulations issued by the federal trade Commission in connection therewith. It is not intended to violate any state law or regulation containing more stringent requirements, and such requirements automatically become part of this warranty insofar as required by that act.

The owner has available the legal remedies provided by the Magnusson-Moss Warranty Act, Public Law 93-637, 99 STAT.2183-2193: 15 U.S.Code, Secs 23021-2312, and any applicable state statutes.

For warranty assistance, contact Air Hitch Technology at 1-866-41-HITCH (1-866-414-4824., weekdays 8:00 AM to 5:00 PM (Central).

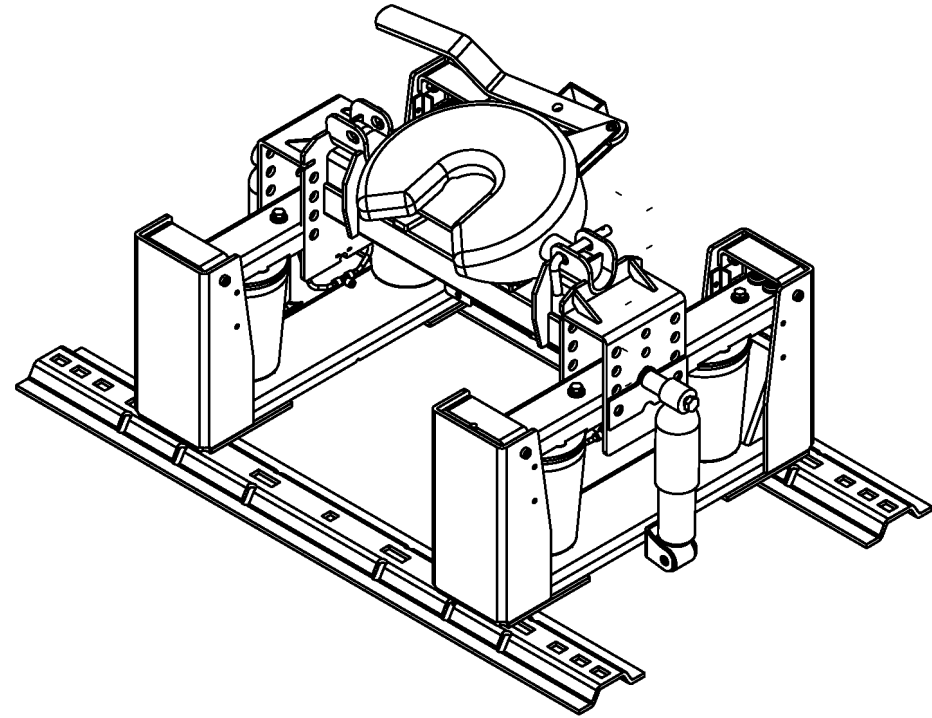

**MODEL # 25027**

**(Binkley 25K)**

**AIR SAFE**

**TOWER HITCH SYSTEM**

***Installation Instructions***

***And***

***User Guide***

# Contents

<b>SAFETY AND CAUTIONS.....</b>	<b>2</b>
<b>PARTS VIEW.....</b>	<b>3</b>
<b>UNPACKING YOUR AIR SAFE HITCH.....</b>	<b>6</b>
<b>HITCH INSTALLATION.....</b>	<b>6</b>
<b>PREPARING FOR FIRST USE.....</b>	<b>8</b>
<b>MAINTAINING YOUR AIR SAFE TOWER SYSTEM.....</b>	<b>10</b>
<b>LIMITED 5 YEAR WARRANTY.....</b>	<b>11</b>

## Maintaining Your Air Safe Tower System

1. Always operate and maintain the hitch head installed with the Air Safe Tower system in accordance with the manufacturer's instructions.
2. After the first 100 miles, and at least once a year thereafter, inspect all bolts for proper tightness. Re-tighten bolts if required. All fasteners should be torqued to 65 ft-lbs unless otherwise stated in the installation instructions (Chapter 1).
3. Periodically inspect your Air Safe Towers and Yoke for wear or damage. If excessive wear or damage is found, contact Air Hitch Technology at 866-41-HITCH (866-414-4824), weekdays 8:00 AM to 5:00 PM (Central)

8. If the jaws have not fully locked, ensure that the kingpin plate is applying downward pressure to the hitch. If necessary, raise the trailer jacks slightly.
9. With the trailer wheels blocked on both sides of the trailers and front and back of the wheels, move the truck slightly back and forth to allow the kingpin to fully engage the jaws.
10. Attach the electrical and breakaway connectors to the proper receptacles in accordance with your coach owner's manual, remove the blocks from the wheels of the coach and double check that the hitch is properly attached to your coach.
11. Inflate the Air Safe Towers until the outer cylinder of the shock is within the green indicated zone.

**Caution: Operation of the hitch with the air bags over or under inflated can cause premature damage to the Air Safe Hitch System.**

12. Fully retract the trailer's front landing gear.

**Once you arrive at your destination, follow these simple steps to properly uncouple your coach from your Air safe Tower Fifth wheel Hitch System.**

1. Block your coach wheels front and rear.
2. If necessary, start your truck and back up against the kingpin to relieve pressure on the locking mechanism. Set the parking brake, put the transmission into park and turn off your vehicle's engine.
3. Extend the front landing gear of the coach until the weight of the coach is just off of the tabletop of the hitch head. Do not exceed 1/16" gap between the bottom plate of the kingpin box and the tabletop of the hitch.

**Caution: Raising the coach too high while still connected can damage the hitch head and other parts of the hitch system, as well as components of your coach. Do not extend the rear stabilizers of the coach prior to or during uncoupling.**

4. Disconnect the electrical and breakaway connectors in accordance with your coach owner's manual.
5. Pull the release pin and pull the lever all the way forward towards the cab of the truck, locking the jaws in the open position.
6. Slowly pull your truck away from the coach.

(Remember when preparing to hook the trailer back up that the handle must be in the middle position to allow the jaws to engage the kingpin.)

## Safety and Cautions

- **Safety is of paramount importance in both installation and use of the Air Safe Tower System. Observe all *Cautions* and *Notes* found in this manual, as well as common sense precautions to ensure safety of yourself and others.**
- **The Air Safe Tower is recommended for use only in regular size truck beds.**
- **The Air Safe Tower Fifth Wheel Hitch System is designed to tow 5th Wheel Trailers with a Gross Vehicle Weight Rating not exceeding any of the component parts. Exceeding the rated capacity is not recommended.**
- **The Air Safe Towers (set of two) are rated for a maximum Gross Vehicle Weight Rating of 25,000 lbs.**
- **The Air Safe Tower Yoke is to be used only with the Hitch Head is designed and sold for.**
- **Install the Air Safe Tower Fifth Wheel Hitch System using bedrails that are rated for the Gross Vehicle Weight Rating of the Hitch Head.**
- **Caution: On all installations there must be a minimum of 5-1/2" clearance between the bottom of the trailer nose and the top of the truck bed sides prior to inflation of the airbags. This is to prevent damage to the truck, trailer or hitch due to lack of clearance.**
- **Caution: Never inflate the Air Safe Tower airbags over 100 psi.**

## Chapter

## 2

## Air Safe Tower Operation and Maintenance

## Preparing for First Use

Your Air Safe Tower is now installed and you're anxious to be on your way down the road. You're almost there, but take a few minutes to ensure your hitch is set up properly for your particular truck/coach combination by following the steps below.

1. Lubricate the top bearing surface of the hitch with automotive type chassis grease, or use a plastic lube plate to provide a lubricated surface. Use engine oil to lubricate pivot points/moving parts within the hitch head.
2. Verify the crossbar is set at the proper height to provide a minimum of 5-1/2" clearance between the bottom of the trailer nose and the top of the truck bed-sides, and allows for a level towing attitude of the coach. If necessary, adjust the crossbar to the proper height, ensuring the fasteners are re-torqued to 65 ft-lbs.
3. Ensure the coach wheels are blocked front and rear, and that the rear stabilizer jacks are fully retracted.
4. Level the coach so that the bottom plate of the kingpin box is level with the tabletop, or "horseshoe" plate, on the top of the hitch head.
5. Retract the hitch head locking mechanism by pulling the hitch head handle toward the front of the truck until the handle locks in the middle position parallel with the tailgate. The release pin that is under the handle will need to be pulled to allow the handle to be moved far enough forward.

**Caution:** When preparing to engage the kingpin, do not move the handle all the way forward allowing the release pin to set in the handle mechanism. This will lock the jaws in the open position and not allow them to close on the kingpin.

6. Slowly back the truck so that the bottom plate of the kingpin box slides onto the tabletop and the kingpin slides fully into the throat of the hitch head. (The jaws of the hitch head will need to tap or hit the kingpin with a little force to get them to release and close around the kingpin.) After the jaws have closed, set the parking brake of the truck and place the transmission into park.
7. Check to ensure that the handle of the hitch head has moved fully rearward, locking the jaws in the closed position. If the handle is still in the middle position, the jaws have not locked closed.

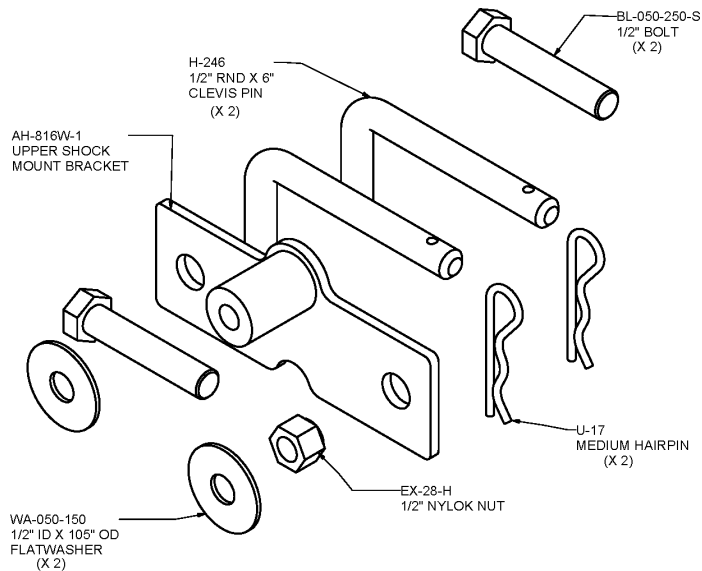
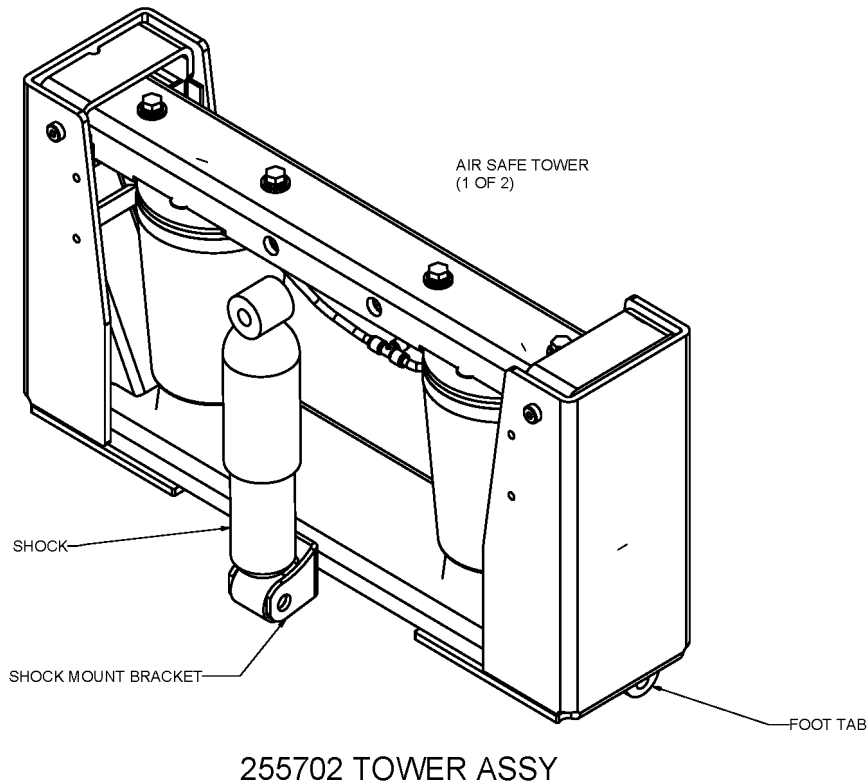

255702 TOWER PARTS BAG

- e) Insert one end of the air hose assembly into the tee at one of the towers, pushing the hose in as far as it will go. Insert the other end into the tee at the other tower.
- f) Place the yoke across the two towers with the pads towards the front of the truck. Align the holes in each end of the yoke with the holes in the tower for the required hitch height. Insert the four U-69-AH 9/16" diameter bolts thru the AH-816W-1 shock mounting plates and then thru the yoke holes and tower holes. Place a U-71-H lock washer on each bolt, and thread on a U-70-H hex nut. Snug down the four bolts and torque to 65 ft-lbs.

(Note: If your yoke hardware bag includes 9/16" diameter flat washers and a shock mounting plate, these parts (along with the 1/2" dia x 4.5" long bolts and 1/2" nuts) are no longer required. Use the mounting plate and hardware that are included with the tower hardware bag.)

- g) Using the EX-Nytie nylon cable ties, secure the air hose to the tabs located on the underside of the yoke. (This will help prevent air leaks due to vibration and movement.)
- h) Install the shocks on each tower. At the lower end, use **one of** the BL-050-250-S 1/2" diameter x 2-1/2" bolt and the EX-28-H nylock nut. At the upper end, use the **other BL-050-250-S** 1/2" diameter X 2-1/2" bolt, using a WA-050-150 washer at each side of the shock lug. Thread the bolt into the upper shock mount and torque to 65 ft-lbs.
- i) Install the hitch head into the cradles of the yoke. Use the H-246 1/2" diameter clevis pins and U-17 medium hairpins to retain the hitch head.

Check for freedom of movement.

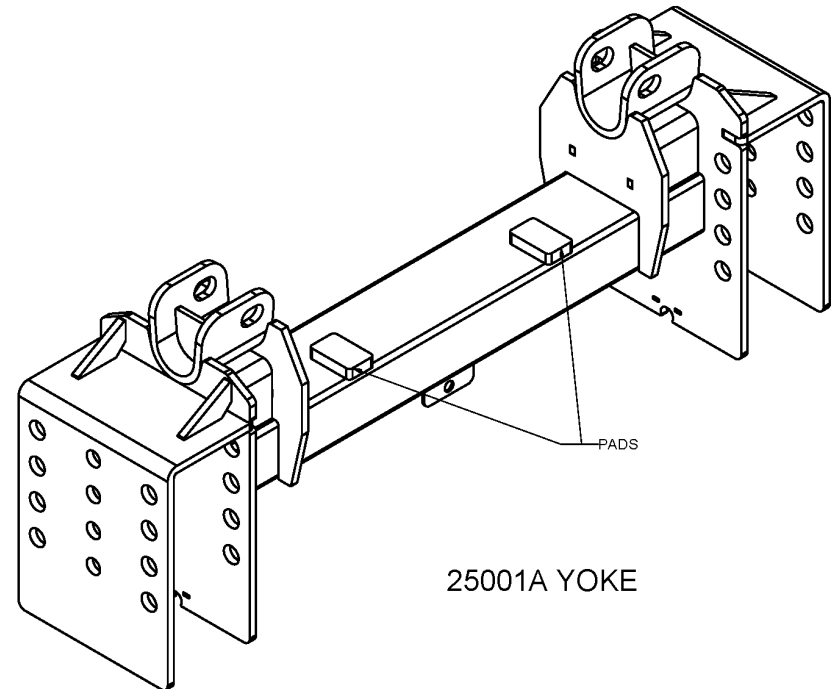

## Unpacking and Installation

1. **Unpacking:** The Air Safe Hitch Assembly ships in three boxes as indicated below. Inspect all parts for damage and verify that all items listed are present

### Box 1 and 2 Contain

- Air Safe Tower (Qty 1 each box)
- Shock (Qty 1 each box)
- Hardware bag (Qty 1 each box)

### Box 3 Contains

- Hitch Head Mount Yoke (Qty 1)
- Hardware Bag (Qty 1)

Hitch head and bed rails are packaged and sold separately.

2. **Hitch Installation:**

- a) Install bed rails per manufacturer's instructions.
- b) For Air Tower Hitches that are being installed as an upgrade to an existing hitch, retain all removed parts and hardware until installation of new system is complete.
- c) (Note: All hardware mentioned below is included in either the Air Tower or the Yoke hardware bags unless otherwise noted.)
- d) Place the foot tabs of the two towers into the appropriate slots in your bed rails for your yoke/hitch head combination. Ensure that the shock mount bracket on each tower is on the outside of the tower. Secure the towers using the H-246 1/2" diameter clevis pins. Secure the clevis pins with the U-17 medium hairpins.

